

TITAN

**Manufacturer, Fabricant, Prodecnt,
Hersteller, Producător, Fabricante:**

UK Manufacturer:

Kingfisher International Products Limited
3 Sheldon Square London W2 6PX
United Kingdom

EU Manufacturer:

Kingfisher International Products B.V.
Rapenburgerstraat 175E 1011 VM Amsterdam
The Netherlands

EN www.diy.com
www.screwfix.com
www.screwfix.ie

To view instruction manuals online,
visit www.kingfisher.com/products

TITAN

Petrol Lawnmower 125 cm³

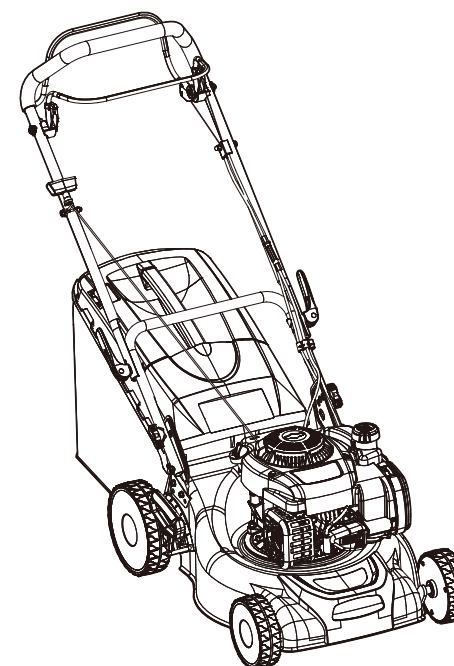

TTLMP300SP40

EAN: 5059340128832

Original Instructions – TTLMP300SP40_EN_V20927

BX220IM/B3



WARNING: Read the instructions before using the product.

TITAN

Congratulations on your purchase of a **TITAN** power tool from Titan Power Tools (UK) Ltd. We want you to continue getting the best performance from it so this handbook includes information on safety, handling and care. Please retain this handbook in case you need to refer to any of the information in the future.

Your power tool comes with a 2 year guarantee, so should it develop a fault within this period contact your retailer.

Guarantee

We take special care to select high quality materials and use manufacturing techniques that allow us to create products incorporating design and durability. This product has a manufacturer's guarantee of 2 years against manufacturing defects, from the date of purchase (if bought in store) or date of delivery (if bought online), at no additional cost for normal (non-professional or commercial) household use.

To make a claim under this guarantee, you must present your proof of purchase (such as a sales receipt, purchase invoice or other evidence admissible under applicable law), please keep your proof of purchase in a safe place. For this guarantee to apply, the product you purchased must be new, it will not apply to second hand or display products. Unless stated otherwise by applicable law, any replacement product issued under this guarantee will only be guaranteed until expiry of the original period guarantee period.

This guarantee covers product failures and malfunctions provided the product was used for the purpose for which it is intended and subject to installation, cleaning, care and maintenance in accordance with the information contained in these terms and conditions, in the user manual and standard practice, provided that standard practice does not conflict with the user manual.

This guarantee does not cover defects and damage caused by normal wear and tear or damage that could be the result of improper use, faulty installation or assembly, neglect, accident, misuse, or modification of the product. Unless stated otherwise by applicable law, this guarantee will not cover, in any case, ancillary costs (shipping, movement, costs of uninstalling and reinstalling, labour etc), or direct and indirect damage.

Rights under this guarantee are enforceable in the country in which you purchased this product. Guarantee related queries should be addressed to the store you purchased this product from.

The guarantee is in addition to and does not affect your statutory rights.

Let's get started...

These instructions are for your safety. Please read through them thoroughly before use and retain them for future reference.



Getting Started...

03

Safety information 04
Your product 13
Before you start 14
Quick start 24



In more detail...

26

Product functions 26
Operation 33
Care and maintenance 37
Troubleshooting 44
Recycling and disposal 46
Customer Care and Technical Helpline 47
Availability of Spare Parts 48
EC declaration of conformity 49

Safety warnings

Petrol powered lawnmowers safety warnings



IMPORTANT

Read carefully before use.
Keep for future reference.



WARNING! Your safety and the safety of others is very important. Of course, it is not practical or possible to warn you about all the hazards associated with operating or maintaining this product. At all times you must use your own good judgment.

Training

1. Read the instructions carefully. Be familiar with the controls and the proper use of the product.
2. Never allow children or people unfamiliar with these instructions to use the product. Local regulations can restrict the age of the operator.
3. Never mow while people, especially children or pets, are nearby.
4. Keep in mind that the operator or user is responsible for accidents or hazards occurring to other people or their property.
5. The operators must receive a proper training in the use, adjustment and operation of the product, including prohibited operations.

Preparation

1. While mowing, always wear protective footwear and long trousers. Do not operate the product when barefoot or wearing open sandals.
2. Thoroughly inspect the area where the product is to be used and remove all stones, sticks, wires, bones, and other foreign objects.
3. **WARNING** - Petrol is highly flammable.
 - Store fuel in containers specifically designed for this purpose.
 - Refuel outdoors only and do not smoke while refuelling.
 - Add fuel before starting the engine. Never remove the fuel tank cap or add petrol while the engine is running or when the engine is hot.
 - If petrol is spilt, do not attempt to start the engine. Move the product away from the area of spillage and avoid creating any source of ignition until fuel vapours have dissipated.
 - Replace all fuel tank and container caps securely.

4. Replace faulty silencers.
5. Before using, always visually inspect to see that the blades, blade bolts and cutter assembly are not worn or damaged. Replace worn or damaged blades and bolts in sets to preserve balance.
6. **CAUTION!** Do not touch rotating cutting means.
7. Engine brake (brake clutch): Use the brake clutch to stop the engine. When you release the clutch, the engine and the blade stop automatically in a few seconds. To mow, hold the bar in the working position. Before you start to mow, check the brake clutch several times to be sure that it is working correctly. Ensure that the brake wire can be smoothly operated (e.g. is not catching or kinking in any way).

Operation

1. Do not operate the engine in a confined space where dangerous carbon monoxide fumes can accumulate.
2. Mow only in daylight or in good artificial light.
3. Do not operate the product while being tired, ill or under the influence of alcohol or drugs.
4. Avoid operating the product in wet grass, where feasible.
5. Always be sure of your footing on slopes.
6. Walk, never run.
7. Mow across the face of slopes, never up and down.
8. Exercise extreme caution when changing direction on slopes.
9. Do not mow excessively steep slopes, near drop-offs, ditches or embankments.
10. Avoid using the product in bad weather conditions especially when there is a risk of lightning.
11. Use extreme caution when reversing or pulling the product towards you.
12. Stop the blade(s) if the product has to be tilted for transportation when crossing surfaces other than grass, and when transporting the product to and from the area to be mowed.
13. Never operate the product with defective guards, shields, or without safety devices, for example mulching insert, deflectors and/or grass catchers, in place.
14. Do not change the engine governor settings or overspeed the engine.
15. Do not alter or tamper with any sealed adjustments for the engine speed control.
16. Do not tamper or disable any product's safety systems or features.
17. Ensure and regularly check that all starting interlocks and operator presence controls are functioning correctly.
18. Stop the product according to instructions in this manual before leaving the operator's position and park it in a safe location.
19. Start the engine carefully according to instructions and with feet well away from the blades.

20. Do not tilt the product when starting the engine or switching on the engine, except if the product has to be tilted for starting. In this case, do not tilt it more than necessary and lift only the part which is away from the operator. Always ensure that both hands are in the operating position before returning the product to the ground.
21. Keep hands and feet away from the cutting means at all times and especially when switching on the engine.
22. Do not put hands or feet near or under rotating parts. Keep clear of the discharge opening at all times.
23. Never pick up or carry a product while the engine is running.
24. In case of any situation mentioned below, stop the engine and disconnect the spark plug connector. Make sure that all moving parts have come to a complete stop:
 - before clearing a blockage or unclogging chute,
 - before checking, cleaning or working on the product,
 - after striking a foreign object. Inspect the product for damage and make repairs as necessary
 - if the product starts to vibrate abnormally (check immediately)
 - > inspect for damage
 - > replace or repair any damaged parts
 - > check for and tighten any loose parts
 - whenever you leave the product
 - before refuelling
25. Never touch the exhaust, exhaust guard or cooling fins when the engine is hot.
26. Never carelessly touch hot parts of the product. While the product is in operation and shortly after that, its parts such as the exhaust, engine, and other surfaces are extremely hot! **Risk of burns!** Pay attention to the markings on the product.
27. Make sure that the air vents of the combustion engine are clear. Keep the air vents free of dust, dirt particles, gases and fumes.
28. Never start or run the engine indoors. The exhaust fumes are dangerous, containing carbon monoxide, an odourless and deadly gas. Operate this product only in well-ventilated outdoor areas.

Maintenance and storage

1. Follow the maintenance and repair instructions of this product. Never carry out any modifications of the product. Never change the preset governor speed or the engine and product settings. Information about maintenance and repair are provided in this instruction manual.
2. Keep all nuts, bolts and screws tight to be sure that the product is in safe working condition.
3. Improper maintenance or using non-genuine parts not recommended by the manufacturer may lead to malfunction/failure of the product. Many accidents are caused by poorly maintained products.

4. Never store the product with petrol in the tank inside a building where fumes can reach an open flame or spark.
5. To reduce the fire hazard, keep the engine, silencer and petrol storage area free of vegetative material and excessive grease.
6. Allow the engine to cool before storing in any enclosure.
7. Check the grass catcher frequently for wear or deterioration.
8. If the fuel tank has to be drained, this should be done outdoors.
9. Wear protective gloves when removing and re-assembling the cutting means.
10. Replace worn or damaged parts for safety. Only use replacement blades and spare parts recommended by the manufacturer.
11. Ensure that only replacement cutting means of the right type are used.

Fuel handling

1. Before refuelling, stop the engine, disconnect the spark plug connector and let the product cool. Fuel and fuel vapours are highly flammable. Take care when handling fuel. Never smoke when you are refuelling the product. Do not refuel the product, if there is an open fire in the vicinity!
2. Always use suitable aids such as funnels and filler necks. Do not spill any fuel on the product or its exhaust system. There is a risk of ignition. Remove spilt fuel carefully from all parts of the product. Any residue which may be present must be completely removed before the product is operated!
3. Fuel fumes can ignite. Never use the product in environments where there is a risk of explosion.
4. Petrol engines produce toxic carbon monoxide exhaust fumes. Breathing carbon monoxide can cause nausea, fainting or even death.
5. Never breathe in any fuel fumes, when you are refuelling the product. Never fill the fuel tank in enclosed spaces, such as basements or sheds. There is a risk of poisoning and explosion!
6. Avoid skin contact with petrol.
7. Do not eat or drink, while you are refuelling the product. If you have swallowed petrol or oil, or if petrol or oil has got into your eyes, then seek medical advice immediately.
8. Close the fuel tank cap immediately after filling the fuel tank. Make sure that it is properly closed.
9. Never use the product without an air filter.
10. Fuel vapour pressure may build up inside the fuel tank depending on the fuel used, weather conditions and the venting system. To reduce the risk of burns and other personal injuries, remove the fuel tank cap carefully to allow any pressure build-up to release slowly.
11. Be aware of fire risks, explosion and inhalation risks.
12. Do not smoke while operating the product, handling fuel or near fuel.
13. Ensure the spark plug connector is securely attached. A loose connector may cause electrical arcing that could ignite combustible fumes and cause a fire or explosion.

14. Check regularly for leaks from the fuel tank cap and fuel lines.
15. Tighten the fuel tank cap thoroughly after refilling the fuel tank.
16. Do not operate the product if it is leaking fuel. Do not remove the fuel tank cap while the engine is running.
17. Use caution when handling fuel. To avoid any accidental fires, move the product at least 3 metres from the fuelling point before starting the engine.
18. Do not store containers filled with fuel or refill the fuel tank in any place where there is a boiler, stove, wood fire, electrical sparks, welding sparks, or other sources of heat or fire which might ignite the fuel.
19. If any fuel spillage occurs during refuelling, use a dry rag to wipe spills and allow remaining fuel to evaporate before starting the engine again.
20. If you have spilt fuel on yourself or on your clothes, change your clothes and wash any part of your body that has come in contact with fuel before starting the engine again.
21. If fuel is ignited, put out the fire with a dry powder fire extinguisher.
22. Store fuel in containers specifically designed for this purpose.

Vibration and noise reduction

To reduce the impact of noise and vibration emission, limit the time of operation, use low-vibration and low-noise operating modes as well as wear personal protective equipment.

Take the following points into account to minimise the vibration and noise exposure risks:

1. Only use the product as intended by its design and these instructions.
2. Ensure that the product is in good condition and well maintained.
3. Use correct attachments for the product and ensure they in good condition.
4. Keep a tight grip on the handles/gripping surfaces.
5. Maintain this product in accordance with these instructions and keep it well lubricated (where appropriate).
6. Plan your work schedule to spread any high vibration tool use across a longer period of time.

Emergency

Familiarise yourself with the use of this product by means of this instruction manual. Memorise the safety directions and follow them to the letter. This will help to prevent risks and hazards.

1. **Always be alert when using this product, so that you can recognise and handle risks early.** Fast intervention can prevent serious injury and damage to property.
2. **Stop the engine and disconnect the spark plug connector if there are malfunctions.** Have the product checked by a qualified professional and repaired, if necessary, before you operate it again.
3. **In case of fire stop the engine and disconnect the spark plug connector.** Take fire-extinguishing measures immediately if the product switch is no longer accessible.



WARNING! Never use water to extinguish the product on fire. Burning fuel must be extinguished with special extinguishing agents! We recommend that you keep a suitable fire extinguisher within reach in your work area! We recommend to have dry powder fire extinguisher always available.

Residual risks

Even if you are operating this product in accordance with all the safety requirements, potential risks of injury and damage remain. The following dangers can arise in connection with the structure and design of this product:

1. Health defects resulting from vibration emission if the product is used over long periods of time or not adequately managed and properly maintained.
2. Injuries and damage to property due to broken application tools or the sudden impact of hidden objects during use.
3. Danger of injury and property damage caused by flying objects.
4. Burns, if touching hot surfaces.





WARNING! This product produces an electromagnetic field during operation! This field may under some circumstances interfere with active or passive medical implants! To reduce the risk of serious or fatal injury, we recommend persons with medical implants to consult their doctor and the medical implant manufacturer before operating this product!















Symbols











On the product, the rating label and within these instructions you will find among others the following symbols and abbreviations. Familiarise yourself with them to reduce hazards like personal injuries and damage to property.

kW	Kilowatt	ml	Millilitre
cm ³	Cubic centimetre	g/kWh	Gram per kilowatt per hour
/min or min ⁻¹	Per minute	kg/h	Kilogram per hour
mm	Millimetre	°C	Degree Celsius
cm	Centimetre	dB(A)	Decibel (A-rated)
kg	Kilogram	m/s ²	Metres per second squared
l	Litre		
yyWxx	Manufacturing date code; year of manufacturing (yy) and week of manufacturing (Wxx)		

Description of signal words:

-  **DANGER!** The signal word that indicates a hazard with a high level of risk which, if not avoided, will result in death or serious injury.
-  **WARNING!** The signal word that indicates a hazard with a medium level of risk which, if not avoided, could result in death or serious injury.
-  **CAUTION!** The signal word that indicates a hazard with a low level of risk which, if not avoided, could result in minor or moderate injury.
- NOTE!** Indicates a practical tip, advice or practice not related to personal injury.

- | | | | |
|--|---|---|---|
|  | Lock/to tighten or secure. |  | Wear respiratory protection. |
|  | Unlock/to loosen. |  | Wear hearing protection.
Wear eye protection. |
|  | Note/Remark. |  | Wear protective gloves
(compliant to EN ISO 21420) |
|  | Caution/Warning. |  | Wear protective, slip-resistant
safety footwear
(compliant to EN ISO 20345) |
|  | Read the instruction manual. |  | Wear tight-fitted protective
clothing (compliant to
EN ISO 13688) |
|  | Mow across the face of slopes, never up and down. | | |
|  | Do not expose the product to rain or wet conditions. | | |
|  | Open flames in the work area, around the product and in the vicinity of flammable materials are prohibited! | | |
|  | Do not smoke in the work area, around the product and in the vicinity of flammable materials! | | |
|  | Risk of fire/flammable materials. | | |

- | | |
|---|--|
|  | Hot surface, do not touch! High temperatures on the product's surfaces and structural parts that could cause burns, if they are touched. The product can also stay hot for a longer period of time after the operation! |
|  | Petrol engines produce toxic carbon monoxide exhaust fumes. Breathing carbon monoxide can cause nausea, fainting or even death. Do not operate the engine indoors! |
|  | Only refuel unleaded petrol! |
|  | Add engine oil. |
|  | Check and refill oil. |
|  | Stop the engine before refuelling the fuel tank. Flammable material. Keep away from fire. Do not add fuel with a running engine. |
|  | Inspect the area where the product is to be used and remove all objects which can be thrown by the product. If objects are hidden while operating, stop the engine and remove the objects. |
|  | Prevent engine malfunction by checking the engine oil level regularly. |
|  | Keep hands and feet away from sharp rotating parts – risk of injury! When cleaning, repairing or inspecting, make sure the cutting means and all moving parts have stopped. Disconnect the spark plug connector, and keep the cap away from the plug to prevent accidental starting. |
|  | Cutting means continues to rotate after the engine is stopped. Wait until all components have completely stopped before touching the product. |
|  | Pay particular attention when working on the blades! |



Objects thrown by the product could hit the operator or other bystanders. Always ensure that other people and pets remain at a safe distance from the product when it is in operation. In general, children must not come near the area where the product is operating.



Release the brake clutch to stop the engine and the cutting means.



Pull the drive bar to engage the wheels.



Switch the product off and disconnect the spark plug connector before assembly, cleaning, adjustments, maintenance, storage and transportation.



Engine manual start, recoil starter.



Keep hands and feet away.



The grass catcher hatch open and close position.



Guaranteed sound power level value in dB.

TTLMP300SP40

Designation of the tool (TT_TITAN; LM_Lawn Mower; P_Petrol power; 300_engine model code; SP_Self-propelled; 40_Cutting width)



The product complies with the applicable European directives and an evaluation method of conformity for these directives was done.

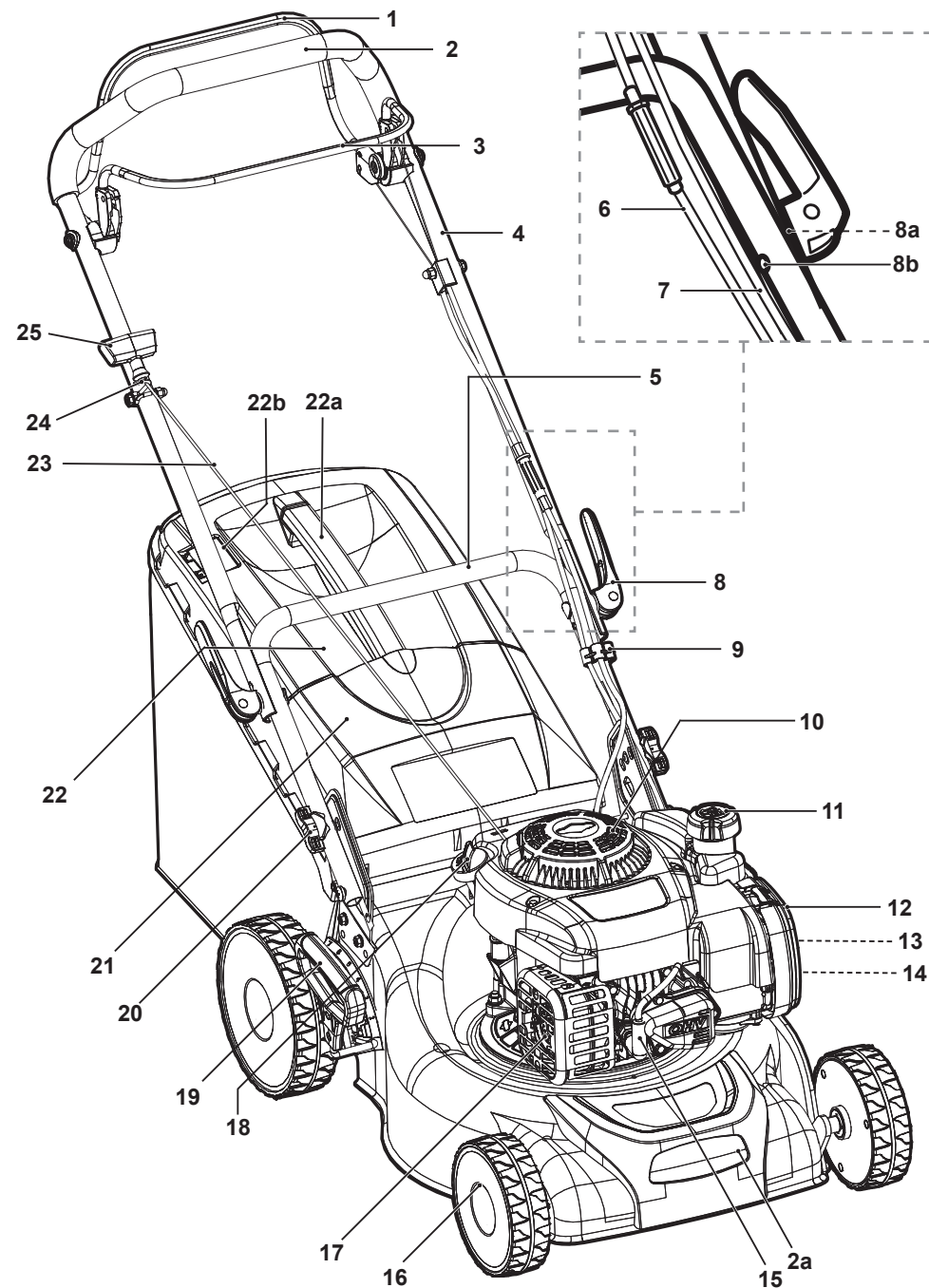

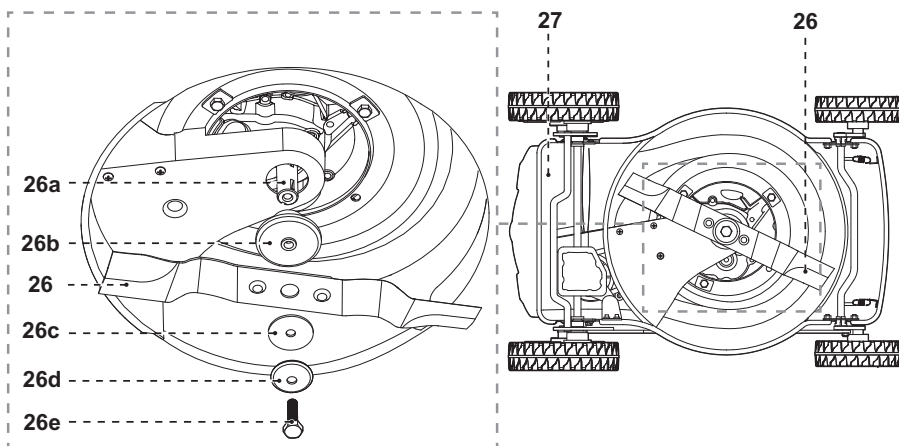

- | | |
|--------------------------|--|
| 1. Drive bar | 18. Oil tank cap with dipstick |
| 2. Handle | 19. Lever for cutting height adjustment |
| a. Transportation handle | 20. Lower handle bar lock |
| 3. Brake clutch | 21. Rear deflector guard |
| 4. Upper handle bar | 22. Grass catcher |
| 5. Lower handle bar | a. Handle |
| 6. Drive wire | b. Hatch |
| 7. Brake wire | 23. Starter wire |
| 8. Side lever (x2) | 24. Hook for recoil starter handle |
| a. Washer * | 25. Recoil starter handle |
| b. Bolt * | 26. Cutting means (blade) |
| 9. Wire clip | a. Spindle |
| 10. Air vents | b. Ring |
| 11. Fuel tank cap | c. Washer |
| 12. Air filter case | d. Locking flange |
| a. Filter * | e. Hex bolt |
| b. Cover * | 27. Rear discharge chute |
| 13. Primer | 28. Mulching insert |
| 14. Water hose connector | a. Unlock button |
| 15. Spark plug connector | 29. Spark plug wrench |
| 16. Wheel | 30. Operator's manual of the
BRIGGS&STRATTON engine |
| 17. Muffler | |



NOTE: Parts marked with * are not shown in this overview. Refer to the respective section in the instruction manual.

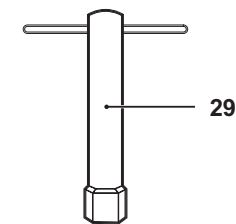
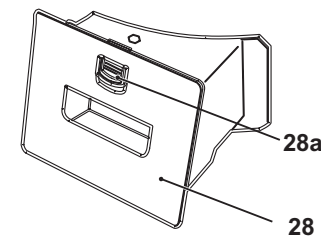

Technical specifications

General

- | | |
|---|---|
| > Dimensions: | approx. 131 x 50.5 x 98.5 cm |
| > Product mass with empty tanks and in the normal operating configuration: | approx. 26 kg |
| > Fuel tank capacity: | 800 ml (cm ³) |
| > Petrol type: | #95, unleaded |
| > Engine oil capacity: | 470 ml (cm ³) |
| > Engine oil type: | 4-stroke engine oil
(e.g. SAE 10W-30) |
| > Specific fuel consumption at max. engine power: | 281 g/kWh |
| > Fuel consumption at max. engine power: | 0.67 kg/h |
| > Cutting means: | blade type: 40 MnB
blade thickness: 3.0 mm |
| > Cutting width: | 41 cm |
| > Cutting height: | 25 - 75 mm |
| > Grass catcher volume: | 50 l |

Engine

- | | |
|---|-----------------------------|
| > Engine model: | B&S300E,08P6 |
| > Engine type: | air cooled, 4-stroke engine |
| > Engine displacement: | 125 cm ³ |
| > Maximum operating engine speed (rotational frequency): | 2800 min ⁻¹ |
| > Nominal power: | 1.7 kW |
| > Spark plug type: | XC92YC |
| > Spark plug gap: | 0.7-0.8 mm |

Sound level

- > **Sound pressure level at operator's position L_{pA} :** 80.3 dB(A)
- > **Uncertainty K:** 3 dB(A)
- > **Sound power level L_{WA} :** 91.3 dB(A)
- > **Uncertainty K:** 1.9 dB(A)
- > **Guaranteed sound power level L_{WA}
(acc. to 2000/14/EC amended by 2005/88/EC):** 96 dB(A)

Vibration level

- > **Hand-arm vibration a_{hw} :** 6.25 m/s²
- > **Uncertainty K:** 1.5 m/s²

The sound values have been determined according to noise test code given in EN ISO 5395-1 and EN ISO 5395-2, using the basic standards ISO 3744 and ISO 11094.

Wear hearing protection, especially when sound pressure is over 80 dB(A).

The declared vibration value has been measured in accordance with a standard test method (according to EN ISO 5395-1 and EN ISO 5395-2) and may be used for comparing one product with another. The declared vibration value may also be used to evaluate the exposure for the user caused by vibration in advance.



WARNING! Depending on the actual use of the product the vibration values can differ from the declared total. Adopt proper measures to protect yourself against vibration exposures. Take the whole work process including times the product is running under no load or switched off into consideration! Proper measures include among others regular maintenance and care of the product and accessories, keeping hands warm, periodical breaks and proper planning of work processes!

Unpacking

NOTE: The product is heavy, ask another person for assistance if required.



1. Unpack all parts and lay them on a flat, stable surface.
2. Remove all packing materials and protective shipping materials, if applicable.
3. Make sure the delivery contents are complete and free of any damage. If you find that parts are missing or show damage do not use the product and contact your dealer. Using an incomplete or damaged product represents a hazard to operators and property.
4. Ensure that you have all the accessories and tools needed for assembly and operation. This also includes suitable personal protective equipment.



WARNING! The product and the packaging are not children's toys! Children must not play with plastic bags, sheets and small parts! There is a danger of choking and suffocation!

You will need**(items not supplied)**

- > Suitable personal protective equipment
- > Fuel funnel with filter
- > Suitable engine oil (SAE10W-30)
- > Suitable fuel (unleaded petrol)
- > Container to collect fuel
- > Container to collect oil
- > Lubrication oil/grease
- > Torque wrench (40-45 Nm)

(advisable items)

- > First aid kit
- > Dry powder fire extinguisher readily available

(items supplied)

- > Spark plug wrench (29)
- > Operator's manual of the BRIGGS&STRATTON engine (30)

Assembly



WARNING! The product must be fully assembled before the operation!



Do not use a product that is only partly assembled or assembled with damaged parts!

Follow the assembly instructions step-by-step and use the pictures provided as a visual guide to assemble the product easily!

Disconnect the spark plug connector (15) from the spark plug! Reconnect it after assembly.



NOTE: Take care of small parts that are removed during assembly or when making adjustments. Keep them secure to avoid loss.

Handle bars

1. Put the product on the flat, stable ground. The lower handle bar (5) is delivered in its storage position.
2. Turn the lower handle bar lock (20) about 90 degrees (Fig. 1). Repeat on the other side to unlock the lower handle bar (5).
3. Unfold the lower handle bar (5) from storage position to working position.
4. Align the pin of the handle bar lock (20) with one of the handle support holes. Turn back the lower handle bar lock (20) and swing the lower handle bar (5) slightly until the handle bar lock (20) clicks in place. Repeat on the other side to secure the position of the lower handle bar (5) (Fig. 2).

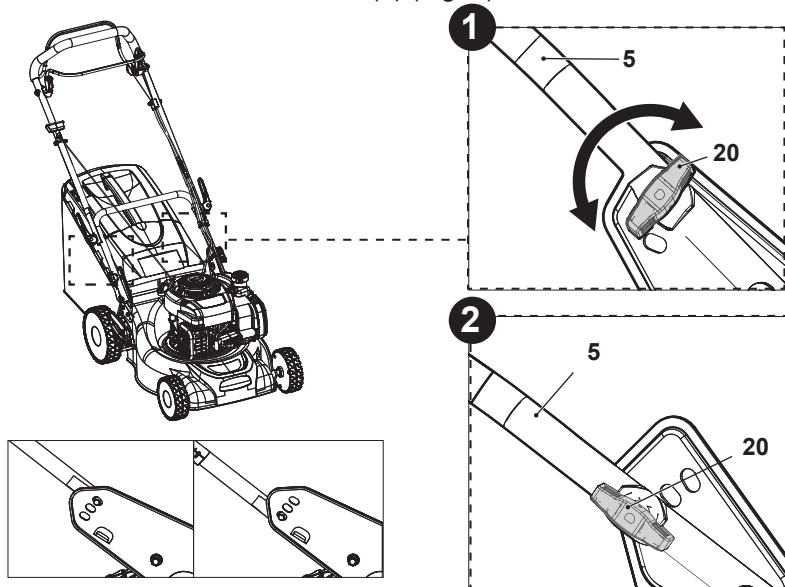

5. Unfold the upper handle bar (4) and hold it with the brake clutch (3) facing upwards. Align the mounting holes of the upper handle bar (4) and the lower handle bar (5) (Fig. 3).

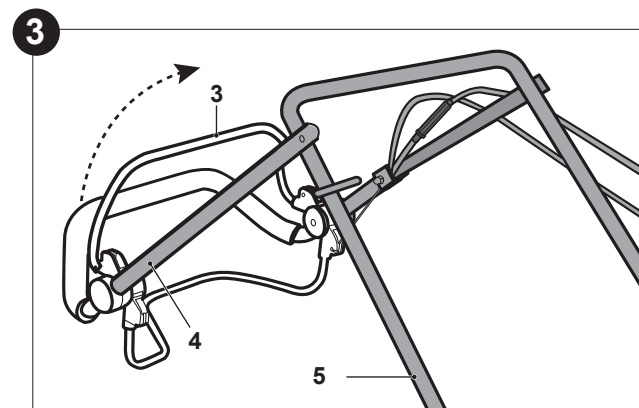

6. Fix the upper handle bar (4) to the lower handle bar (5) with the side levers (8), washers (8a) and bolts (8b) through the mounting holes (Fig. 4). Screw in the side lever (8) clockwise and lock by folding up towards the handle. If side lever (8) cannot be folded, loosen it and fold again (Fig. 5). If it is too loose, tighten it by swinging the side lever (8).



NOTE: Do not overtighten the side levers (8). If it is difficult to lock the side lever (8), rotate it in the opposite direction to loosen the connection.

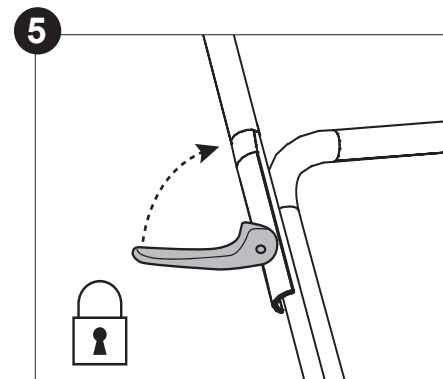
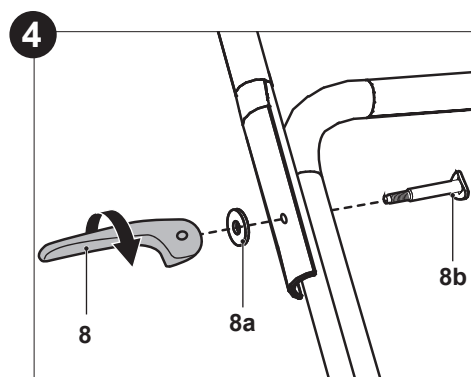

Grass catcher installation



NOTE: Always carry the grass catcher (22) by its handle (22a).

1. Lift the rear deflector guard (21) and hold it in place (Fig. 6).
2. Align the hooks of the grass catcher (22) with the rods and hang them onto.
3. Carefully release the rear deflector guard (21) afterwards.

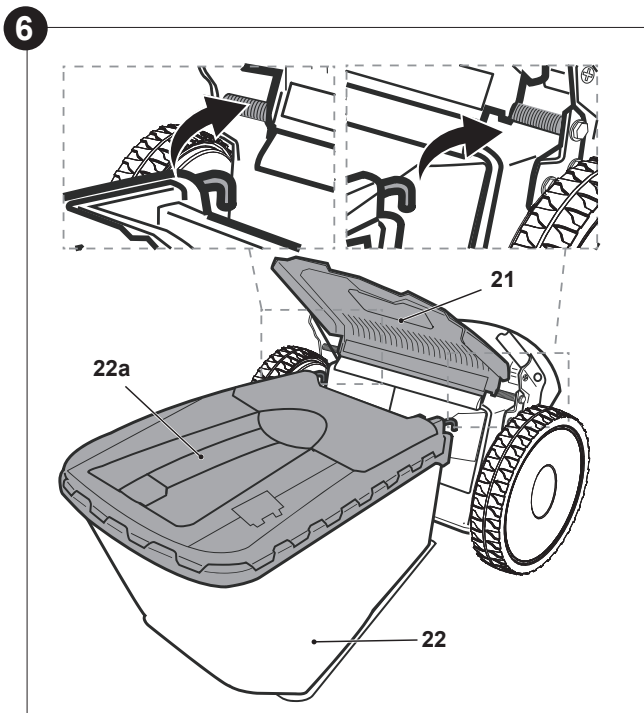

Fuel and engine oil

This product is equipped with a 4-stroke engine. Before operation, it is necessary to add suitable fuel and engine oil separately.



WARNING! This product contains an operator's manual of the BRIGGS&STRATTON engine (30). Service the engine with proper petrol and engine oil as instructed in the separate operator's manual of the BRIGGS&STRATTON engine (30).



It is important to read and understand these instructions of the engine and the equipment.

SAVE THESE ORIGINAL INSTRUCTIONS FOR FUTURE REFERENCE.



WARNING! Fuel and oil are highly inflammable! Fumes will explode if lit! Ensure that there are no naked flames around the product! Do not smoke while filling fuel and oil!



- > Use proper funnels. Avoid spilling and overfilling the tanks.
- > Always dispose of fuel, used oil and objects contaminated with them in accordance with local regulations.

Fuel



NOTE: This product is not supplied with fuel! Before operating, it is essential to fill it with fuel! Fill fuel and engine oil separately. Never mix oil with fuel!



- > Always use clean, fresh unleaded petrol. Purchase fuel in quantities that can be used up within 30 days.
- > Avoid getting dirt, dust or water in the fuel tank.

1. Place the product on a stable, level surface. We recommend laying a non-flammable sheet under the product.
2. Unscrew and remove the fuel tank cap (11) (Fig. 7).

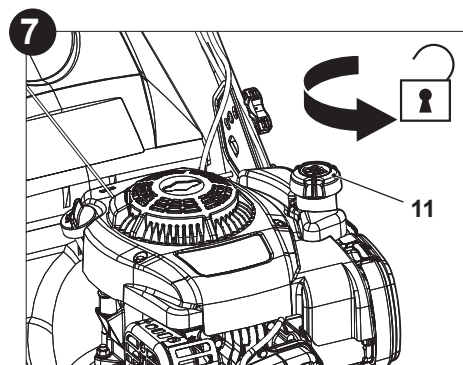

3. Add suitable fuel into the fuel tank. Leave a minimum 5 mm of space between the top of the fuel and the inside edge of the tank to allow for expansion (Fig. 8).

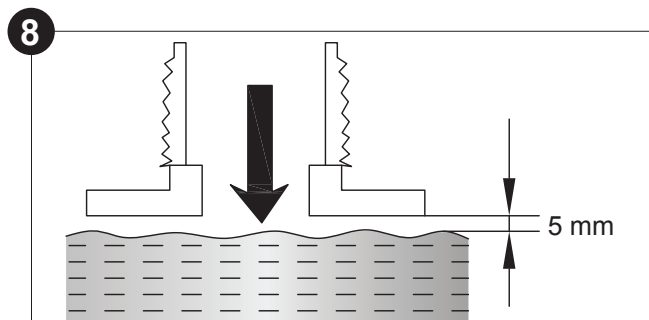

4. Wipe any spilt fuel with a soft cloth and reattach the fuel tank cap (11).



NOTE: Petrol deteriorates over time. It may be difficult to start the engine if you use petrol which has been kept for more than few days. Empty the fuel after every use. Run the product dry of fuel in idle before storage.



NOTE: Fuel can damage paint and plastic. When filling the tank, take care not to spill any fuel. Damages caused by spills are not covered by the guarantee.

Engine oil



WARNING! This product is not supplied with oil. However, for manufacturing reasons, it is possible that a small quantity may be in the engine! Before operating this product, it is essential to fill it with oil (4-stroke engine oil, e.g. SAE 10W-30)!

Engine oil has a significant influence on engine performance and service life. Non-detergent or 2-cycle engine oils will damage the engine and should not be used - see the separate operator's manual of the BRIGGS&STRATTON engine (30).

1. Place the product on a flat and even surface.
2. Unscrew and remove the oil tank cap (18).
3. Gradually add good-quality engine oil (SAE 10W-30). Allow the oil to settle.
4. Check the oil level frequently while filling. Wipe off oil dipstick and insert it into the tank opening without tightening the cap, and then remove the dipstick again.
5. The oil level must be between the oil level markings (approx. 400 ml). Add more oil if necessary. Do not overfill (Fig. 9).

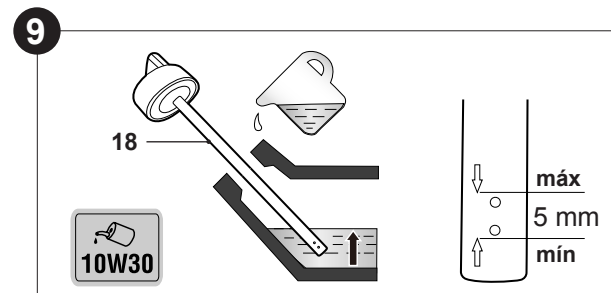

6. After filling oil, wait 1 minute and then recheck the oil level.
7. Wipe the spilt oil with a soft cloth and reattach the oil tank cap (18).

Operating controls

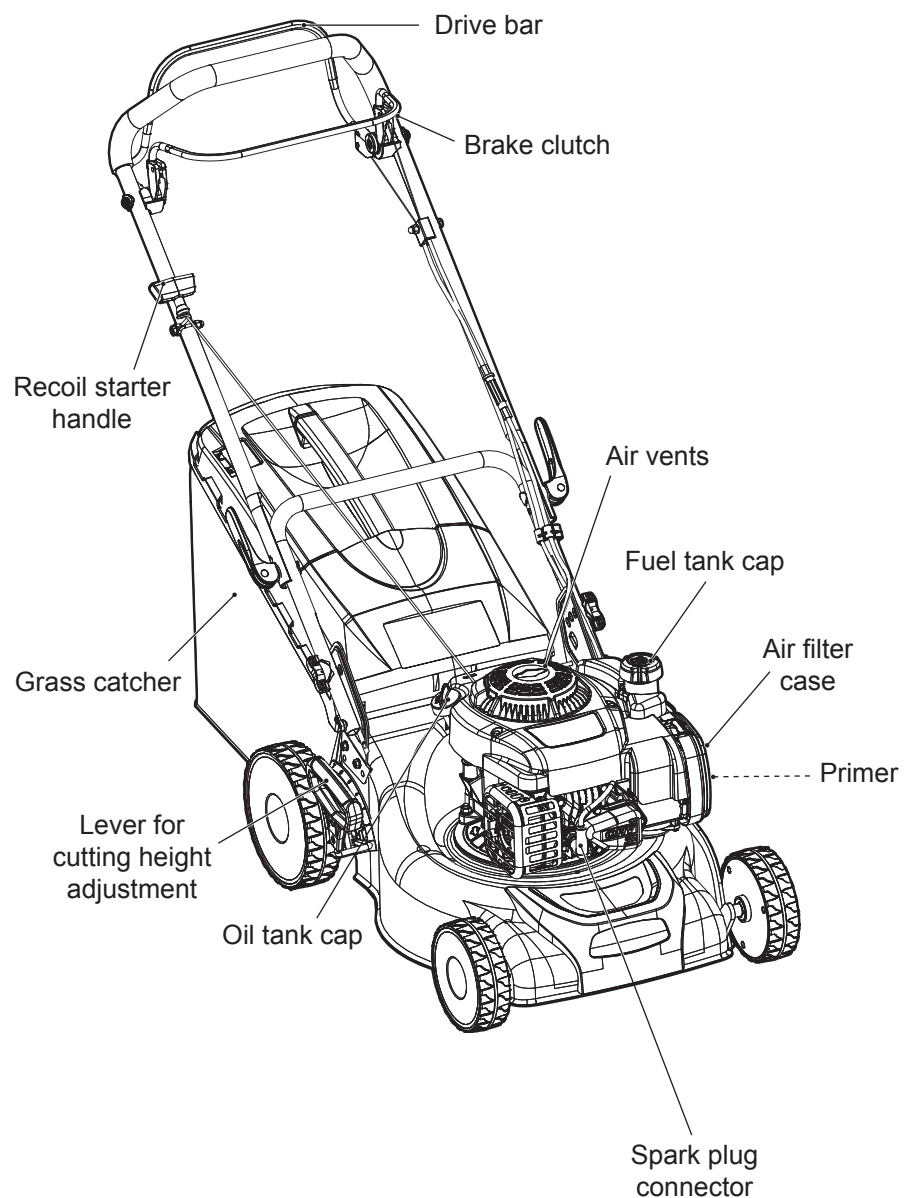

Preparation



Assemble



Adjust



Add fuel



Add oil

Cold start



Press primer 3 to 5 times



Pull and hold brake clutch



Pull recoil starter, repeat until engine starts



Pull and hold drive bar



Operate

Warm start



Pull and hold brake clutch



Pull recoil starter, repeat until engine starts



Pull and hold drive bar



Operate

Stopping



Release drive bar



Release brake clutch

Storage



Empty fuel tank



Empty oil



Clean and maintain



Store



WARNING! This quick start provides only a short overview of how to start and stop the product! For safe use it is essential to read the entire instruction manual before first use!

Intended use

This petrol lawnmower MLMP300SP40 is designated with a power output of 1.7 kW.

1. The product is intended for mowing grass in domestic gardens only. It must not be used to mow unusually high, dry or wet grass (e.g. pasture grass) or for shredding leaves.
2. For safety reasons it is essential to read the entire instruction manual before the first operation and to observe all the instructions therein.
3. This product is intended for private domestic use only, not for any commercial use. It must not be used for any purposes other than those described.

Handle adjustment



NOTE: There are 3 locking holes on the handle supports of both sides. Choose one of the holes to lock the lower handle bar (5) according to the desired height of the handle (2).

1. Turn the lower handle bar lock (20) about 90 degrees (Fig. 10). Repeat on the other side to unlock the lower handle bar (5).
2. Adjust the lower handle bar (5) to the desired height by aligning the pin of the handle bar lock (20) with one of the handle support holes (Fig. 10).
3. Turn back the lower handle bar lock (20) and swing the lower handle bar (5) slightly until the handle bar lock (20) clicks in place. Repeat on the other side to secure the position of the lower handle bar (5) (Fig. 11).

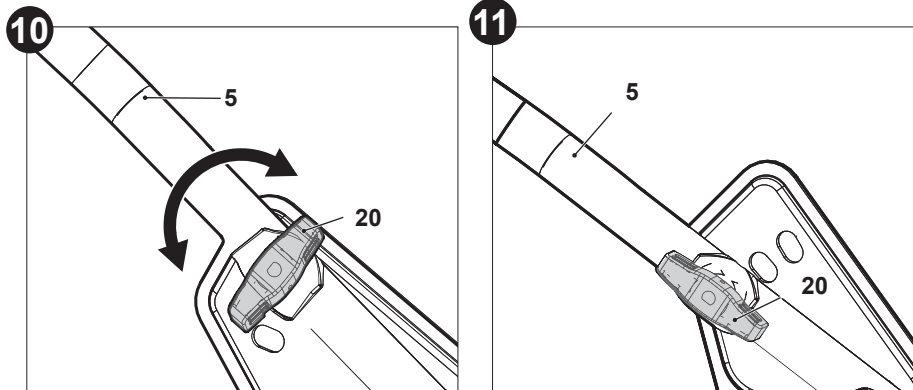

Brake clutch

1. Pull the brake clutch (3) towards the handle (2) and hold it in position when starting the engine and during operation (Fig. 12).
2. Release the brake clutch (3) to stop the engine.

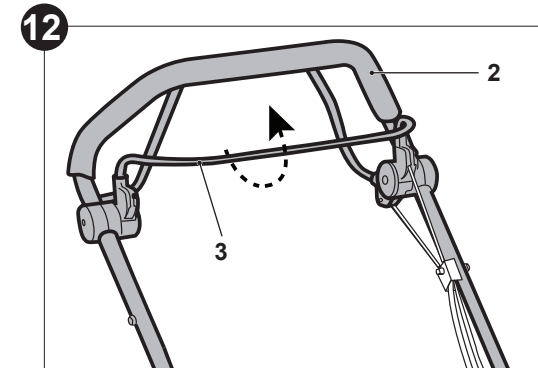

Drive bar (self-propelled function)

Use the self-propelled function as assistance during operation; the rear wheels (16) are automatically driven by the engine; you do not need to push the product manually.

1. When the engine is running, pull the drive bar (1) towards the handle (2) to engage the wheels (16) (Fig. 13).
2. Release the drive bar (1) to disengage the wheels (16).

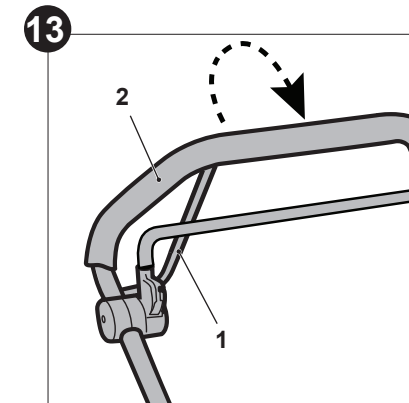

Recoil starter

The recoil starter handle (25) is positioned at the top of the engine.

1. Pull the brake clutch (3) towards the handle (2) and hold it in position.
2. Stand behind the handle (2).
3. Place the recoil starter handle (25) onto the hook (24) located on the right-hand side of the upper handle bar (4) (Fig. 15).
4. Pull the recoil starter handle (25) lightly until you feel resistance then pull it rapidly. Do it repeatedly until the engine starts (Fig. 14).
5. During operation rest the recoil starter handle (25) onto the hook (24) (Fig. 15).

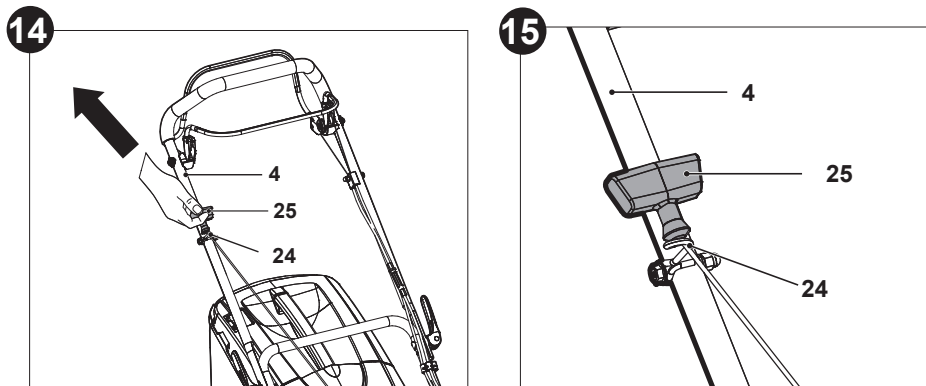

WARNING! Never twist the starter cord around your hand! Only pull on the recoil starter handle (25)!



WARNING! Do not sudden the recoil starter handle (25)! Allow the rope to return slowly and in a controlled manner each time it is pulled!

Grass catcher

The grass catcher (22) is equipped with a hatch (22b) that indicates the filling volume during operation.

1. When the hatch (22b) is opened the grass catcher (22) has enough volume left to collect grass (Fig. 16).
2. When the hatch (22b) is closed the grass catcher (22) is full and must be emptied (Fig. 17).

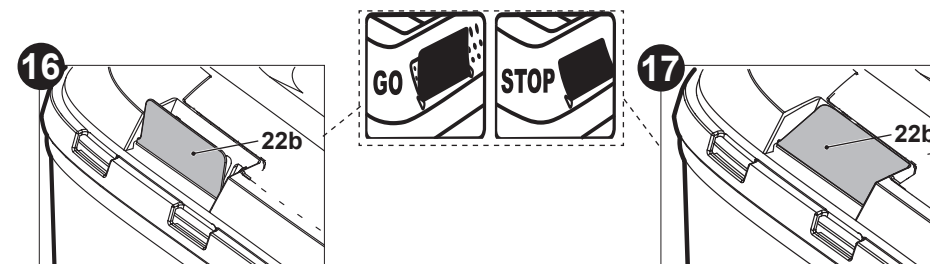

WARNING! Always attach the grass catcher (22) when using this product - danger of flying objects! Always carry the grass catcher by its handle (22a).

Emptying



WARNING! Before removing the grass catcher (22) stop the engine and wait until the blade (26) comes to a complete stop.

Empty the grass catcher (22) frequently during use. Do not wait until it is full. We recommend emptying when it is 90% full.



NOTE: A full grass catcher (22) reduces the performance of the product.

1. Lift the rear deflector guard (21) and hold it in place.
2. Lift the grass catcher hooks off the rods and place the grass catcher (22) on the ground.
3. Remove the grass clippings from the rear discharge chute (27) into the grass catcher (22). Use a proper tool such as a brush.



WARNING! Never use your hands or feet to remove grass clippings from the rear discharge chute (27)!

4. Empty the grass clippings onto a compost heap.
5. Re-fit the grass catcher hooks (22) onto the rods.

Grass catcher inspection

During use the grass catcher (22) material is subjected to normal wear and tear. An excessively worn grass catcher may allow the objects to be thrown towards the operator. Replace a worn grass catcher to prevent possible injury.

Mulching insert



NOTE: Mulching means cutting and returning the grass clippings to the lawn in one step: the grass clippings are cut very fine and then distributed evenly back onto the lawn. Under normal conditions, the mulched grass will biodegrade quickly to provide nutrients to the lawn.

1. Open the rear deflector guard (21), hold it in position and insert the mulching insert (28) into the rear discharge chute (27) (Fig. 18). Ensure the unlock button (28a) snaps in place.
2. Press the unlock button (28a) to release and remove the mulching insert (28) (Fig. 19).

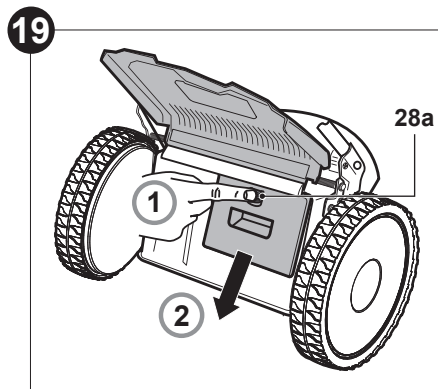
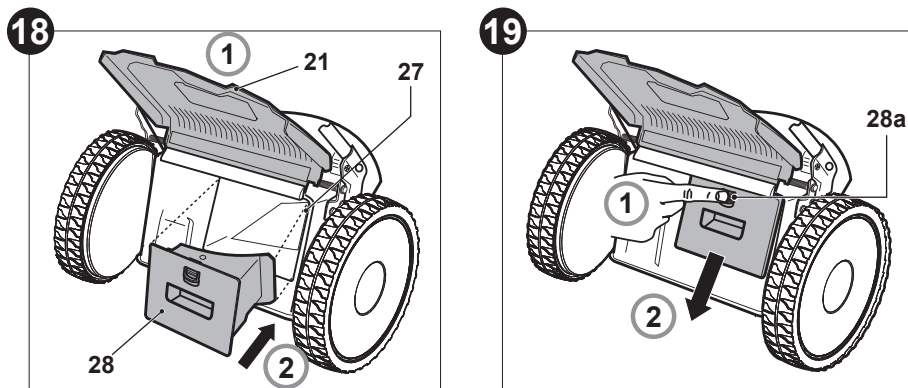

Cutting height adjustment



WARNING! Before adjusting the cutting height, stop the engine and wait until the blade (26) comes to a complete stop.

This product can be adjusted to 7 different height settings. New or thick grass may require a higher cutting height and a narrower cutting path.

1. Pull the lever for cutting height adjustment (19) towards the wheel (16) (Fig. 20, step 1), and then move it forward or backward to the desired cutting height (Fig. 20, step 2).
2. Release the lever (19) and ensure it engages into place properly.



NOTE: If you are not sure what cutting height should be selected, start with a maximum height and check the appearance of the lawn after mowing a small area. Adjust the setting if necessary.

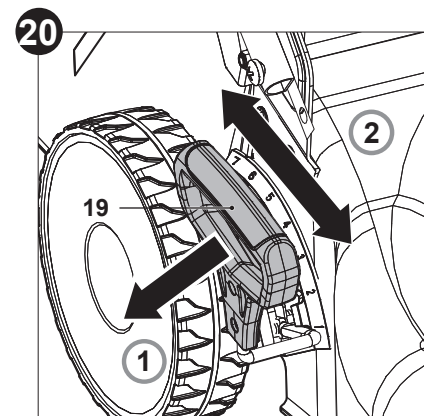

WARNING! Ensure that the lever (19) engages between two of the grooves!

Primer

The primer (13) is positioned in the middle of the air filter case (12). Use the primer (13) when starting the product with cold engine (Fig. 21).

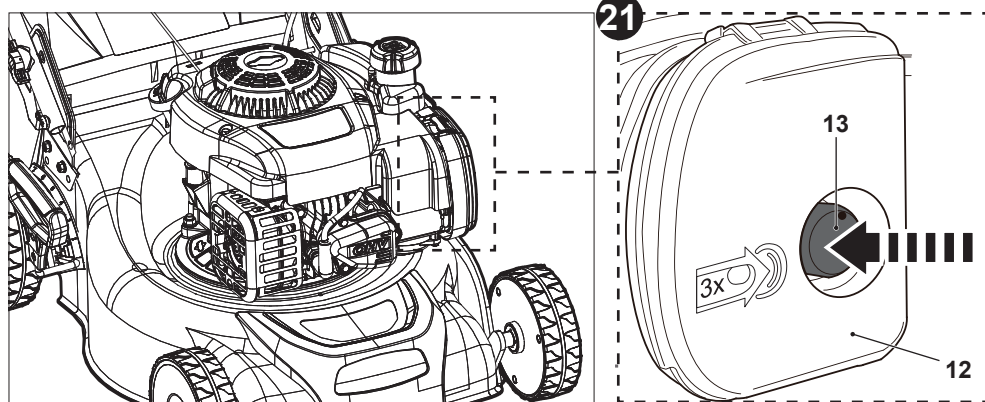

General operation tips

- Before each use:
 - > Check the product and accessories for damage and whether they are properly fixed. Do not use the product if it is damaged or shows signs of wear and tear. Take care of any problem you find or have the product checked by qualified specialist.
 - > Check the fuel and oil level. Refill if necessary.
 - > Look around and underneath the product for signs of oil or fuel spill.
 - > Check each control for proper operation.
 - > Check blades (26) for wear.
 - > Make sure that all bolts and screws are tightened.
 - > Check if the air filter (12a) is clean.
- Always push the product using the handle (2). Keep the handle bar dry and free from lubricant to ensure safe support.
- Ensure that the air vents (10) are always unobstructed and clear. Clean them if necessary with a soft brush. Blocked air vents may lead to overheating and damage the product.
- Stop the engine immediately if you are disturbed while working by other people entering the working area. Always let the blades (26) come to a complete stop before leaving the product unattended.
- Do not overwork yourself. Take regular breaks to ensure you can concentrate on the work and have full control over the product.

Cold start



WARNING! Before starting, place the product on a stable, level surface free of high grass! Clean the underside of the product!

Start the engine carefully according to instructions. Keep your feet well away from the blade (26).

Stay ready. The product starts moving forward once you pull the drive bar (1) towards the handle.

Do not tilt the product when starting the engine.

- Press the primer (13) 3 to 5 times (Fig. 22).
- Pull the brake clutch (3) towards the handle (2) and hold it in position (Fig. 23).
- Stand behind the handle (2).
- Place the recoil starter handle (25) onto the hook (24) located on the right-hand side of the upper handle bar (4) (Fig. 25).
- Pull the recoil starter handle (25) lightly until you feel resistance then pull it rapidly. Do it repeatedly until the engine starts (Fig. 24).

6. During operation rest the recoil starter handle (25) onto the hook (24) (Fig. 25).

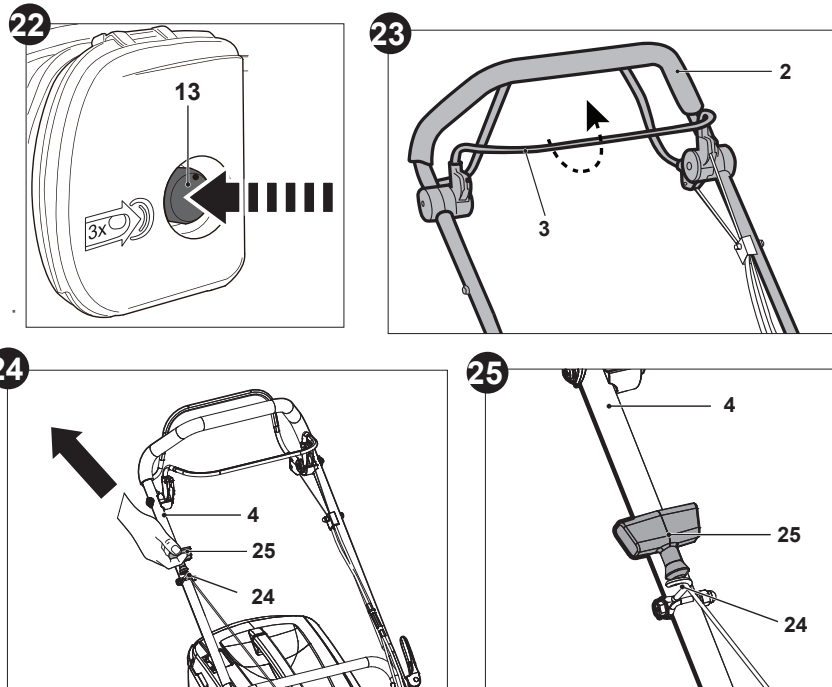

7. Hold the brake clutch (3) and pull the drive bar (1) towards the handle (2) (Fig. 26). The product moves forward and starts mowing.

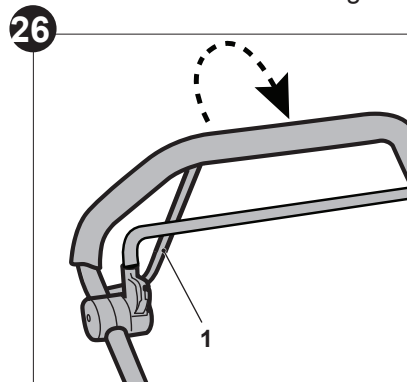

WARNING! The starting position should be as described in the instruction manual. Fig. A illustrates the defined starting position. The operator should start the engine behind the handle (2). Do not start the engine while standing on the side of the product as shown on Fig. B.

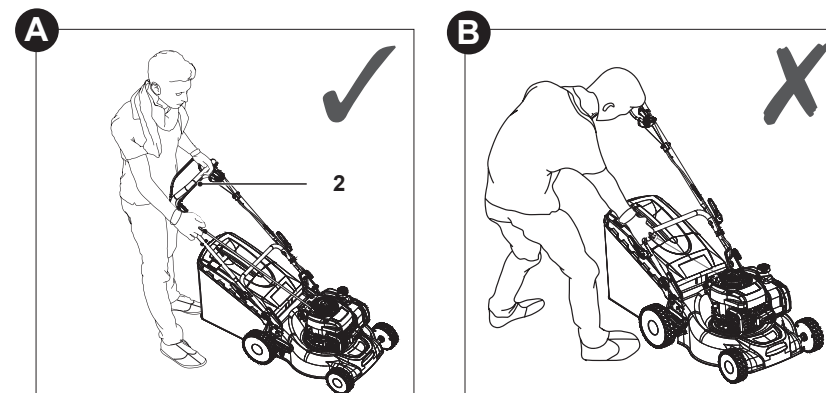

Warm start

1. Pull the brake clutch (3) towards the handle (2) and hold it in position (Fig. 23).
2. Stand behind the handle (2).
3. Place the recoil starter handle (25) onto the hook (24) located on the right-hand side of the upper handle bar (4) (Fig. 25).
4. Pull the recoil starter handle (25) lightly until you feel resistance then pull it rapidly. Do it repeatedly until the engine starts (Fig. 24).
5. During operation rest the recoil starter handle (25) onto the hook (24) (Fig. 25).
6. Hold the brake clutch (3) and pull the drive bar (1) towards the handle (2) (Fig. 26). The product moves forward and starts mowing.



NOTE: If the engine does not start, it may be flooded. Flooding is caused by too much fuel injected into the combustion chamber and can prevent the engine from starting. To resolve flooding follow the below procedure:

1. Remove the spark plug located under the spark plug connector (15) and dry it - see the separate operator's manual of the BRIGGS&STRATTON engine (30).
2. Wait for 10 minutes until fuel vapours and refit the spark plug. Clean up any spilt fuel and move the product at least 3 metres away before starting the engine to avoid any accidental fire.
3. Start the engine.

Stopping

1. Release the drive bar (1) to stop the self-propelled function.
2. Release the brake clutch (3) to stop the engine and blade (26) (Fig. 27).

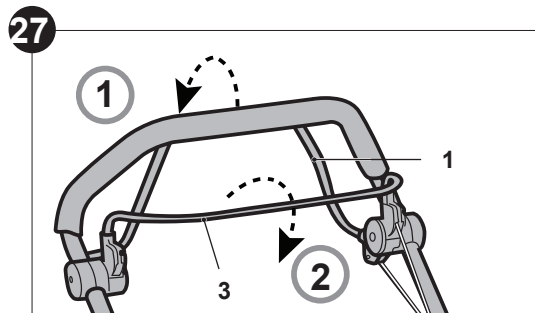

Mowing



NOTE: Avoid mowing when the grass is wet from rain or dew. Wet grass may form clumps which interfere with the mulching action and reduce runtime. The best time to mow grass is late afternoon when the grass is dry and the newly cut area will not be exposed to direct sunlight.

Preparing the product according to required application

Function	Grass catcher (22)	Mulching insert (28)
Grass collection	installed	removed
Mulching	removed	installed

General tips

1. Make sure that the lawn is clear of stones, sticks, wires or other objects that could damage the product or its engine.
2. Do not cut wet grass because it tends to stick to the underbody of the product, preventing the proper discharge of grass clippings, and it could also cause you to slip and fall.
3. Never cut off more than one-third of the total length of the grass for a healthy lawn. In the autumn, lawns should only be cut as long as there is growth.
4. Slowly push the product forward. If needed, use the self-propelled function for assistance.
5. Mow in slightly overlapping rows. The most effective pattern for mowing lawns is straight lines along one of the sides. This keeps the rows even and ensures that all the lawn is cut without missing any spots (Fig. 28).
6. Circle around flower beds. When reaching a flower bed in the middle of the lawn, cut a row or two around the circumference of the bed.
7. Pay particular attention when changing direction.
8. Empty the grass catcher (22) regularly.

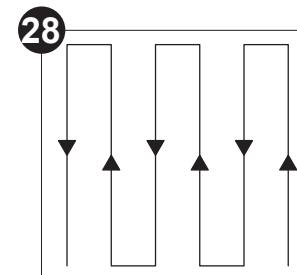

WARNING! Extensive vibration of the product during operation is an indication of damage! Stop the engine immediately. The product should be promptly inspected and repaired!

The golden rules for care



DANGER! Proper maintenance is essential for safe and trouble free operation. Improper maintenance, or failure to address a problem instantly can cause a malfunction which can result in serious injury or even death.



WARNING! Stop the engine, disconnect the spark plug connector (15) and let the product cool before performing inspection, maintenance and cleaning work!



Do not touch the rotating blade (26).

1. Keep the product clean. Remove debris after each use and before storage.
2. Regular and proper cleaning helps to ensure safe operation and prolongs the life of the product.
3. Inspect the product before each use for worn and damaged parts. Do not operate it if you find broken and worn parts. Replace worn parts as necessary or contact an authorised service centre for repair before using the product again.



WARNING! Only perform repairs and maintenance work according to these instructions! All further works must be performed by a qualified specialist!

Cleaning

1. Clean the product with a slightly damp cloth and mild soap. Use a brush for areas that are hard to reach.
2. In particular, clean the air vents (10) after every use with a cloth and brush.
3. Remove stubborn dirt with high pressure air (max. 3 bar).
4. Clean the underbody and cutting means (26) using the water hose connector (14).



NOTE: Do not use chemical, alkaline, abrasive or other aggressive detergents or disinfectants to clean this product as they might be harmful to its surfaces.

Maintenance

Before and after each use, check the product and accessories for wear and damage. If required, exchange them for new ones as described in this instruction manual. Observe the technical requirements.



WARNING! It is required to tip the product when performing the maintenance. The fuel tank must be empty, or fuel can leak which could result in fire or explosion.



NOTE: Always empty the fuel tank and keep the spark plug upside down. Otherwise, the fuel or engine oil might contaminate the air filter (12a)/spark plug and might make it difficult start the engine.

After use

1. Stop the engine, disconnect the spark plug connector (15) and let the product cool.
2. Check, clean and store the product as described in the maintenance table.

Maintenance table with schedules

Part	To do	Before/ after each use	First month or 5 hours	Every 3 months or 25 hours	Every 6 months or 50 hours	Every year or 100 hours	Every 2 years or 250 hours
Engine oil	check	x					
	replace				x		
Air filter	check	x					
	clean replace			x			x
Spark plug	check/ adjust			x			
	clean replace			x			x
Spark plug cap	clean					x	
Fuel tank	clean						
Fuel tube	clean						
Cutting means	replace						

Every 2 years (replace if necessary)

Replace the cutting means (26) after 50 hours of mowing, or 2 years whichever is sooner regardless of condition.

Underbody and cutting means



WARNING! Wear protective gloves when working on the cutting means (26) and close to it! Use proper tools to remove debris, e.g. a wooden stick! Never use your bare hands!



Always use original spare parts for replacement. The cutting means (26) must be replaced by an identical type with the reference number DAYE 2105200264. Do not attach any other type of cutting means (26)!

The replacement of the cutting means (26) should be done by an experienced operator! Rework or sharpening blades is not recommended unless it is done by a repair service or a similarly qualified specialist!



NOTE: We strongly recommend jacking the product when performing inspection and work on the cutting means (26). Avoid tilting the product in order to prevent fuel and oil leakages.

1. Keep the underbody and cutting means (26) clean and free of debris. Remove clippings from the rear discharge chute (27).
2. Check all nuts and bolts periodically for tightness before the operation. After prolonged use, especially in sandy soil conditions, the cutting means (26) will become worn and lose some of the original shape. The cutting efficiency will be reduced, and the cutting means (26) should be replaced.
3. Keep the cutting means (26) sharp to ensure a good cutting performance. Replace a worn or damaged cutting means with a new one of the same type or have it sharpened by a qualified specialist.
4. If jacking the product is not possible, tilt it to the right side so that the fuel tank cap (11) side is up. This helps to prevent fuel leakage and harder starting due to flooding of the carburettor.
5. Loosen the hex bolt (26e) anti-clockwise and remove it together with the locking flange (26d), washer (26c) cutting means (26), and ring (26b) (Fig. 29).
6. Replace the cutting means (26) with a new one of the same type. Slide the ring (26b) into the slot on the spindle (26a) and then refit the cutting means (26), washer (26c), locking flange (26d) and hex bolt (26e). Tighten the hex bolt clockwise with 40-45 Nm force to ensure safe operation of the product (Fig. 29).



DANGER! If the cutting means (26) are not torqued properly, they could become loose and be thrown from the product and seriously hurt or kill the operator or bystanders.



NOTE: Replace the cutting means (26) after 50 hours of mowing, or 2 years whichever is sooner regardless of condition. If the cutting means (26) is cracked or damaged, replace it immediately.

7. Lubricate the cutting means (26) after each use to prolong their life span. Apply lubrication oil/grease along the edges of the cutting means (26).

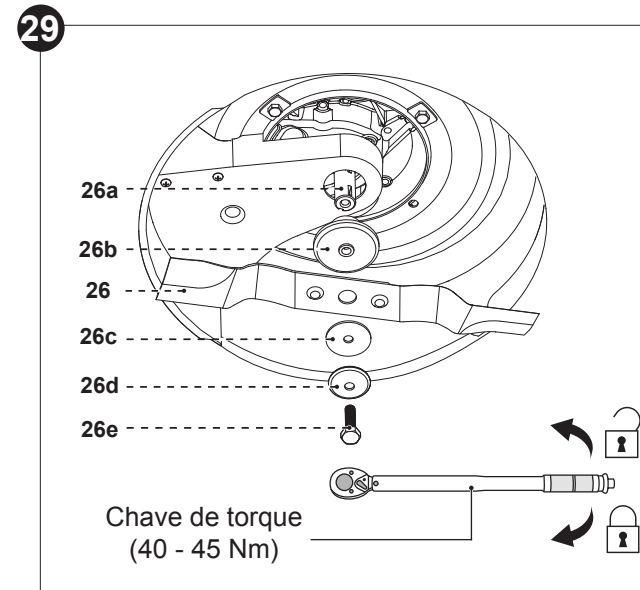

Underbody and cutting means cleaning



NOTE: Do not use pressure washer for cleaning. It may force water to enter the vital areas of the product.

1. Set the cutting height to the lowest position using the lever (19).
2. Connect a water hose with a quick connector to the water hose connector (14) (Fig. 30). Turn on the water supply.



NOTE: A quick connector must be used to connect the water hose and the connector (14).

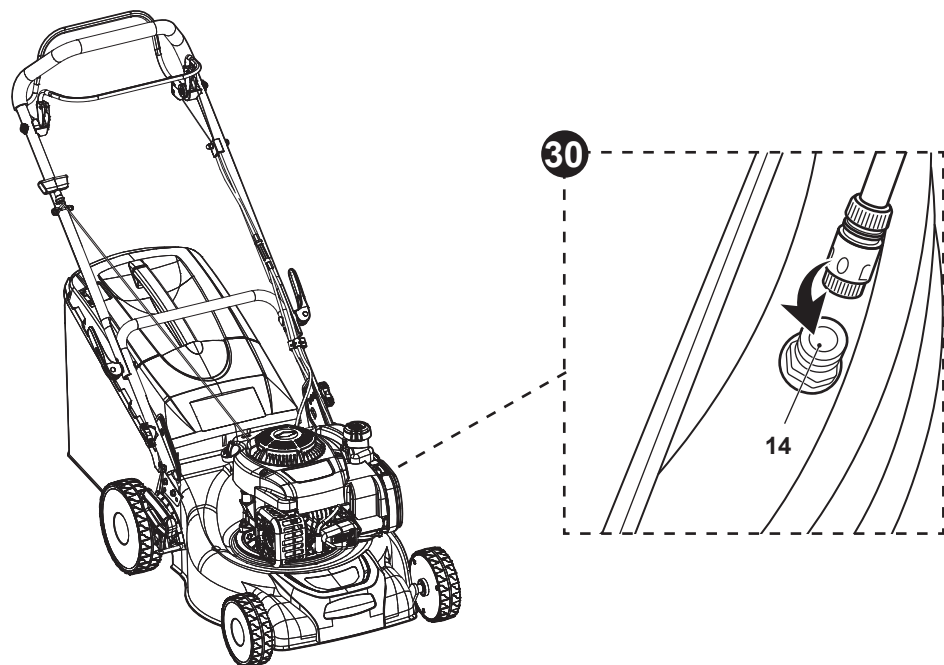

3. Start the engine and keep holding the brake clutch (3). Keep flushing for 1 minute.
4. When the grass clippings stop coming out of the underbody, stop the engine.
5. Turn off the water supply and detach the water hose from the water hose connector (14).
6. Start the engine and let it run for 2 minutes to dry the underbody.

Grass catcher

1. Inspect the grass catcher (22) before each use. Do not use it if you find any damage.
2. Clean the grass catcher (22) after operation using water.
3. Let the grass catcher (22) dry thoroughly before storing.

Brake and drive wires

Check the performance of the brake wire (7) and the drive wire (6) before each use. Ask a qualified specialist to adjust it if necessary.



WARNING! Do not use the product with a defective or loose wires!

Spare parts

The parts mentioned in the maintenance table may be replaced by the consumer. Spare parts are available at an authorised dealer or through our customer service.

Description	Model no. or Specification
Blade	DAYE 2105200264

Engine maintenance

Refer to the operator's manual of the BRIGGS&STRATTON engine (30) for maintaining below parts:

- > Air filter
- > Spark plug
- > Fuel
- > Engine oil
- > Carburettor
- > Valve play
- > Muffler

Repair and service

This product does not contain any parts that can be repaired by the consumer. Contact an authorised service centre or a similarly qualified specialist to have it checked and repaired.

Only an Authorized Briggs & Stratton dealer can perform warranty repairs on the Briggs&Stratton engine.

Use the Parts & Repair Dealer Locator on BRIGGSandSTRATTON.com to locate an engine dealer nearest you.

For service of the product outside of the engine, contact Sertronics by helpline 0800 4840045 or Email: ServiceKF-UK@sertronics.de.

Storage



NOTE: Good storage conditions are important for keeping your product trouble-free.

1. Stop the engine and disconnect the spark plug connector (15).
2. Clean the product as described in the "Cleaning" section.
3. Loosen the side levers (8). Unlock the lower handle bar lock (20) and fold the lower (5) and the upper handle bars (4).
4. Store the product and its accessories in a well-ventilated dry storage area.
5. Always store the product in a place that is inaccessible to children. The ideal storage temperature is between 10 °C and 30 °C.

6. We recommend using the original package for storage or covering the product with a suitable cover or enclosure to protect it against dust.
7. For long-term storage (more than 5 days), drain the fuel tank as described in operator's manual of the BRIGGS&STRATTON engine (30).

Transportation

1. Stop the engine and disconnect the spark plug connector (15).
2. Adjust the height to the highest position as described in the "Cutting height adjustment" section.
3. Attach transportation guards, if applicable.
4. Always move the product by the handle (2).
5. If a suitable loading ramp is not available, ask another person for assistance when loading the product on a vehicle.
6. Protect the product from any heavy impacts or strong vibrations which may occur during transportation in vehicles.
7. Secure the product with tie-down straps to prevent it from slipping or falling over.

Troubleshooting

Suspected malfunctions are often due to causes that the operators can fix themselves. Therefore, check the product using this section. In most cases, the problem can be solved quickly.



WARNING! Only perform the steps described in these instructions! All further inspection, maintenance and repair work must be performed by an authorised service centre or a similarly qualified specialist if you cannot solve the problem yourself!

Problem	Possible cause	Solution
1. Engine does not start	1.1 Not enough fuel in the fuel tank	1.1 Add fuel
	1.2 Spark plug is wet	1.2 Dry spark plug
	1.3 Spark plug is damaged	1.3 Replace spark plug
	1.4 Spark plug connector is loose	1.4 Attach properly
	1.5 Lever for cutting height adjustment is not in the correct position for the prevailing conditions	1.5 Move the lever to correct position
	1.6 Air filter is dirty	1.6 Clean the air filter
	1.7 Spark plug is loose	1.7 Tighten the spark plug (25 to 30 Nm)
	1.8 Spark plug gap is incorrect	1.8 Set gap between electrodes between 0.7-0.8 mm
	1.9 Faulty ignition module	1.9 Contact an authorised service centre
2. Engine stops	2.1 Not enough fuel in the fuel tank	2.1 Fill fuel
	2.2 Cutting mean is blocked	2.2 Remove blockage
3. Engine difficult to start or loses power	3.1 Dirt, water or stale fuel in the fuel tank	3.1 Drain fuel and clean tank. Fill the tank with clean, fresh fuel
	3.2 Vent hole in fuel tank cap is clogged	3.2 Clean or replace the fuel tank cap
	3.3 Air filter is dirty	3.3 Clean air filter
4. Engine operates erratically	4.1 Spark plug is defective	4.1 Install new, correctly gapped plug
	4.2 Spark plug gap is incorrect	4.2 Set gap between 0.7-0.8 mm
	4.3 Air filter is dirty	4.3 Clean air filter

Problem	Possible cause	Solution
5. Engine idles poorly	5.1 Air filter is dirty 5.2 Air vents are clogged 5.3 Cylinder fins are blocked	5.1 Clean air filter 5.2 Remove debris from vents 5.3 Remove debris from cylinder fins
6. Engine skips at high speed	6.1 Gap between electrodes of the spark plug is too close	6.1 Set gap between 0.7-0.8 mm
7. Engine overheats	7.1 Air vents are clogged 7.2 Incorrect spark plug	7.1 Remove debris from vents 7.2 Install the correct spark plug
8. Unsatisfactory results	8.1 Cutting mean is dull 8.2 Cutting height is incorrect	8.1 Replace with a new one 8.2 Adjust cutting height
9. Excessive vibration/noise or exhaust	9.1 Cutting mean is dull/damaged 9.2 Bolts are loose 9.3 Incorrect petrol type	9.1 Replace with a new one 9.2 Tighten all bolts 9.3 Drain the fuel and fill the correct type

Recycling and disposal

1. Old products are potentially recyclable and do not, therefore, belong in your household rubbish. You are requested to assist us and our contribution to saving resources and protecting the environment by handing in this product to an equipped collection centre (if there is one available).
2. Petrol, oil, used oil, a mixture of oil and petrol and objects soiled with oil e.g. cleaning cloths do not belong in the household rubbish. Dispose of oil-contaminated items in accordance with the local guidelines and hand them in at recycling centres.
3. The product comes in a package that protects it against damage during shipping. Keep the package until you are sure that all parts have been delivered and the product is operating properly. Recycle the package afterwards.





Customer Care and Technical Helpline

A better way to repair your tools

Kingfisher takes special care in creating high-quality garden power tools that are designed to last. But if a fault develops with your garden power tool and you need to claim under the guarantee, the Customer Care and Technical Helpline can support with technical assistance or if required, arrange a free courier collection from your home, assess your garden power tool for fault, repair it, and return it.

Deciding to repair your product rather than buying a replacement and adding to the mountain of waste is a more sustainable choice and you will be doing your bit for the environment.

How does it work?

				
Step 1 Find your proof of purchase and get in touch with the Customer Care and Technical Helpline.	Step 2 Chat to them about the problem with your tool.	Step 3 They will provide technical and user advice or alternatively arrange a courier collection from your home.*	Step 4 The team will assess and test and if necessary, repair your product back to full working order.	Step 5 Your repaired tool will be returned to you via courier within 5 to 7 working days*.



NOTE: please note that before collection, all fuel must be removed from petrol powered machines.

Get in touch

If you need help or more information, please contact the Customer Care and Technical Helpline:

UK: 0800 0789647

Eire: 1800 932226

Opening hours are Monday – Friday, 8am-5pm

Availability of Spare Parts

Contact the customer service helpline for assistance or visit www.kingfishersparses.com

For assistance contact the customer services helpline:

UK 0800 0789647 uk@Kingfishersservice.com

EIRE 1800 932226 eire@kingfishersservice.com

Further information about this product can also be found at:

www.kingfisher.com/products



(EN) EU DECLARATION OF CONFORMITY
 (FR) DÉCLARATION UE DE CONFORMITÉ
 (PL) DEKLARACJA ZGODNOŚCI UE
 (RO) DECLARAȚIA DE CONFORMITATE UE
 (ES) DECLARACIÓN UE DE CONFORMIDAD
 (PT) DECLARAÇÃO DE CONFORMIDADE UE

Product/ Produit/ Produkt/Produsul/Producto/Produto

- > Petrol lawnmower/Tondeuse à gazon thermique/Kosiarka spalinowa/Mașină de tuns iarba cu benzină/Cortacésped de gasolina/Cortador de grama a gasolina
- > TTLMP300SP40
- > 125cm³, 1.7kW
- > 000001 - 999999

Name and address of the manufacturer or his authorised representative:

Nom et adresse du fabricant ou de son mandataire:

Nazwa i adres producenta lub jego upoważnionego przedstawiciela:

Denumirea și adresa producătorului sau a reprezentantului său autorizat:

Nombre y dirección del fabricante o de su representante autorizado:

Nome e endereço do fabricante ou do respetivo mandatário:

Kingfisher International Products B.V.,
 Rapenburgerstraat 175E,
 1011 VM Amsterdam,
 The Netherlands

This declaration of conformity is issued under the sole responsibility of the manufacturer.

La présente déclaration de conformité est établie sous la seule responsabilité du fabricant.

Niniejsza deklaracja zgodności wydana zostaje na wyłączną odpowiedzialność producenta.

Prezenta declarație de conformitate este emisă pe răspunderea exclusivă a producătorului.

La presente declaración de conformidad se expide bajo la exclusiva responsabilidad del fabricante.

A presente declaração de conformidade é emitida sob a exclusiva responsabilidade do fabricante.

Object of the declaration/Objet de la declaration/Przedmiot deklaracji/Obiectul declarației/Objeto de la declaración/Objeto da declaração

Product/Produit/Produkt/Produsul/Producto/Produto	Model/Modèle/Model/Modelul/Modelo/Modelo	EAN
Petrol lawnmower/Tondeuse à gazon thermique/Kosiarka spalinowa/Mașină de tuns iarba cu benzină/ Cortacésped de gasolina/Cortador de grama a gasolina	TTLMP300SP40	5059340128832

The object of the declaration described above is in conformity with the relevant Union harmonisation legislation:

L'objet de la déclaration décrit ci-dessus est conforme à la législation d'harmonisation de l'Union applicable:

Wymieniony powyżej przedmiot niniejszej deklaracji jest zgodny z odnośnymi wymaganiami unijnego prawodawstwa harmonizacyjnego:

Obiectul declarației descris mai sus este în conformitate cu legislația relevantă de armonizare a Uniunii:

El objeto de la declaración descrita anteriormente es conforme con la legislación de armonización pertinente de la Unión:

O objeto da declaração acima descrito está em conformidade com a legislação de harmonização da União aplicável:

2006/42/EC as amended Machinery Directive
 2014/30/EU as amended Directive Electromagnetic compatibility
 2000/14/EC as amended Outdoor Noise Directive
 2016/1628/EU Regulation Gaseous and Particulate Pollutant Emission Limits
 2011/65/EU as amended Directive Restriction of the use of certain hazardous substances in electrical and electronic equipment
 Directive 2006/42/CE relative aux machines
 2014/30 / UE telle que modifiée Directive Compatibilité électromagnétique
 Directive 2000/14/CE relative aux émissions sonores extérieures
 Règlement (UE) 2016/1628 relatif aux exigences concernant les limites d'émission pour les gaz polluants et les particules polluantes
 Directive 2011/65/UE relative à la limitation de l'utilisation de certaines substances dangereuses dans les équipements électriques et électroniques
 2006/42/WE w zmienionej dyrektywie maszynowej
 2014/30 / UE ze zmianami Dyrektywa Kompatybilność elektromagnetyczna
 2000/14/WE w zmienionej dyrektywie w sprawie hałasu na zewnątrz
 2016/1628/UE limity emisji zanieczyszczeń gazowych i cząstek stałych
 2011/65 / UE ze zmianami Dyrektywa Ograniczenie stosowania niektórych niebezpiecznych substancji w sprzęcie elektrycznym i elektronicznym
 2006/42/CE, astfel a fost modificată Directiva privind echipamentele
 2014/30/UE, astfel a fost modificată Directiva privind compatibilitatea electromagnetică
 2000/14/CE, astfel a fost modificată Directiva privind zgomotul în aer liber
 2016/1628/UE Regulamentul privind emisiile de poluanți gazoși și de particule poluante
 2011/65/UE, astfel a fost modificată Directiva privind limitarea utilizării anumitor substanțe periculoase în echipamentele electrice și electronice
 Directiva sobre maquinaria modificada 2006/42/CE
 2014/30/UE modificada Directiva Compatibilidad electromagnética
 2000/14/CE modificada Directiva sobre ruido al aire libre
 2016/1628/Reglamento de la UE Límites de emisiones de contaminantes gaseosos y partículas
 2011/65/UE modificada Directiva Restricción del uso de determinadas sustancias peligrosas en equipos eléctricos y electrónicos
 2006/42/CE como diretiva de máquinas alteradas
 2014/30/UE como alteração da compatibilidade eletromagnética
 2000/14/CE como diretiva de ruído exterior alterada
 Limites de emissão de poluentes gasosos e de poluentes de partículas 2016/1628/REGULAMENTO da UE
 2011/65/UE como restrição diretiva alterada da utilização de certas substâncias perigosas em equipamentos elétricos e eletrônicos

Measured Sound Power Level

Guaranteed Sound Power Level

Le niveau de puissance acoustique mesuré

Le niveau de puissance acoustique garant

Zmierzony poziom mocy akustycznej

Gwarantowany poziom mocy akustycznej

Nível de putere acustică măsurat

Nível de putere acustică garantat

Nível de potencia sonora medido

Nível de potencia sonora garantizado

Nível de potência sonora medido

Nível de potência sonora garantido

: 91.3 dB(A)

: 96 dB(A)

Engine Model/Modèle de moteur/Model silnika/Modelul motorului/Modelo de motor/Modelo de motor:
 08P6 (300E)

The notified body/ l'organisme notifié / Jednostka notyfikowana / Organismul notificat / Organismo notificado / Organismo notificado: TÜV SÜD Industrie Service GmbH, No 0036

Certificate registration number/ Numéro d'enregistrement du certificate/Number rejestracyjny certyfikatu /Nr.de inregistrare a certificatului / Numero de registro del certificado / Numero do certificado de registo: OR/005531/101

Test report No./ Numéro du rapport de test/ Numer raportu / Raport test nr. /N.0 del informe de prueba/ Ralatorio de teste no: 704032032124

Conformity assessment procedures: Annex VI of the directive / Procédures d'évaluation de conformité : Annexe VI de la Directive/ Procedury oceny zgodności: Załącznik VI dyrektywy / Proceduri de evaluare a conformitatii: Anexa VI a directivei / Procedimientos de evaluacion de la conformidad : Anexo VI de la directiva / Procedimentos de avaliacao de conformidade: Anexo VI da diretiva

References to the relevant harmonised standards used or references to the other technical specifications in relation to which conformity is declared:

Références des normes harmonisées pertinentes appliquées, y compris la date de celles-ci, ou des autres spécifications techniques, y compris la date de celles-ci, par rapport auxquelles la conformité est déclarée:

Odwolania do odnośnych norm zharmonizowanych, które zastosowano, wraz z datą normy, lub do innych specyfikacji technicznych, wraz z datą specyfikacji, w odniesieniu do których deklarowana jest zgodność:

Trimiteri la standardele armonizate relevante folosite, inclusiv data standardului, sau trimiteri la celelalte specificații tehnice, inclusiv data specificațiilor, în legătură cu care se declară conformitatea:

Referencias a las normas armonizadas pertinentes utilizadas, incluidas las fechas de las normas, o referencias a las otras especificaciones técnicas, incluidas las fechas de las especificaciones, respecto a las cuales se declara la conformidad:

Referências às normas harmonizadas aplicáveis utilizadas, incluindo a data da norma, ou às outras especificações técnicas, incluindo a data da especificação, em relação às quais é declarada a conformidade:

EN ISO 5395-1:2013/A1:2018 / EN ISO 5395-2:2013/A2:2017 / EN ISO 14982:2009 / EN ISO 3744:1995

Authorised signatory and technical file holder/signataire et responsable de la documentation technique autorisée/ podmiot uprawniony do wystawienia i adres prezechowywania dokumentacji technicznej/ semnatar autorizat și deținător al dosarului tehnic/firmante autorizado y titular del expediente tecnico/ signatário autorizado e detentor da ficha técnica

Kingfisher International Products B.V.,
 Rapenburgerstraat 175E,
 1011 VM Amsterdam,
 The Netherlands



David Awe
 Group Quality Director

: 2021-08-12



(UK) DECLARATION OF CONFORMITY

Product

- > Petrol lawnmower
- > TTLMP300SP40
- > 125cm³, 1.7kW
- > 000001 - 999999

Name and address of the manufacturer or his authorised representative:

Kingfisher International Products Limited
3 Sheldon Square
London W2 6PX
United Kingdom

This declaration of conformity is issued under the sole responsibility of the manufacturer.

Object of the declaration

Product	Model	EAN
Petrol lawnmower	TTLMP300SP40	5059340128832

Supply of Machinery (Safety) Regulations 2008 as amended
Noise Emission in the Environment by Equipment for Use Outdoors Regulations 2001 as amended
The Non-Road Mobile Machinery (Type-Approval and Emission of Gaseous and Particulate Pollutants) Regulations 2018 as amended
Electromagnetic Compatibility Regulations 2016 as amended
The Restriction of the use of Certain Hazardous Substances in Electrical and Electronic Equipment Regulations 2012 as amended
Measured Sound Power Level: 93 dB(A)
Guaranteed Sound Power Level: 96 dB(A)
Engine Model: 08P6 (300E)
Approved Body 0359, Intertek Testing & Certification Limited
UKCA Certificate number: 21UK-ONR-0020-R03; Report Number: 210401037HZH-001+A1

References to the relevant designated standards used or references to the other technical specifications in relation to which conformity is declared:

EN ISO 5395-1:2013/A1:2018 / EN ISO 5395-2:2013/A2:2017 / EN ISO 14982:2009 / EN ISO 3744:1995

Authorised signatory and technical file holder:

Kingfisher International Products Limited
3 Sheldon Square
London W2 6PX
United Kingdom

Kingfisher International Products B.V.,

David Awe
Group Quality Director

On 2021-08-12